

## Volume X Paper Y

---

# Comparison of ENM, EIS and DC Resistance for Assessing and Monitoring Anti-Corrosive Coatings

Dr Douglas J Mills

*School of Applied Sciences, University College Northampton, St George's Avenue Northampton, NN2 6JD, UK, [Douglas.Mills@Northampton.ac.uk](mailto:Douglas.Mills@Northampton.ac.uk)*

### Abstract

This paper provides a brief review of the (mainly in-situ) electrochemical methods that have been applied to coatings to assess corrosion protection ability. It discusses particularly the electrochemical noise method (ENM) which although still being developed has shown considerable promise as a method for assessing coatings in a laboratory situation. Results are presented and compared with results from other electrochemical methods particularly Electrochemical Impedance Spectroscopy (EIS). The challenge of how best to apply ENM and other methods to monitoring in a practical situation is addressed.

### Keywords

Anti-Corrosive Coatings, Electrochemical methods, Electrochemical Noise Method

## **Introduction**

Traditional Approaches to accelerated testing/lifetime prediction involve preparing panels with scribes on and then subjecting them either to Cabinet Tests e.g. Salt Spray Testing – ASTM B117 (ISO 7253) hot 5% salt spray for typically 1000hrs or external exposure for a year or several years or both. At the end of these tests assessment of condition of panel/coating is generally done by eye using some sort of rating scale such as ISO 4628, ASTM D610(corrosion), D614(blistering). Adhesion is also sometimes measured e.g. using ISO 4624 the Pull Off test or ISO 2409 Cross Cut adhesion.

Disadvantages of traditional methods are that they are expensive and time consuming (particularly external exposure). The favourite industry cabinet test i.e. continuous exposure to hot 5% Chloride salt spray is unfair to some systems. This makes it difficult to quickly formulate new products with either improved anti-corrosion resistance or similar but using more environmentally friendly products. In relation to the latter there is a move towards cycling cabinet tests using solutions like diluted Harrison's solution (0.35% Ammonium Sulphate, 0.05% sodium chloride) as specified in ASTM D 7894.

## **Electrochemical Methods (general)**

Early work done by Bacon et al [1] examined 300 coatings systems in sea water using a resistance measuring device (a simple measurement like measuring internal resistance of a battery). They found systems with resistance of 100 megohms-cm<sup>2</sup> conferred good protection, those

between 1 megohm and 100 megohms-cm<sup>2</sup> were fair, and those less than 1 megohm-cm<sup>2</sup> were poor. These ranges and subsequent expectation of behaviour are still largely in use today. Between 1948–1973 not much happened in terms of further instrumentation development. However during the latter half of this period Dr Mayne's laboratory in Cambridge was looking at Ionic Resistance properties of detached varnishes and paints to try to understand mechanism and establish a theoretical basis for the observations of Bacon et al. Discrete anodes and cathodes were observed on polystyrene implying that resistance control was important and in 1973 an instrumentation improvement (Keithley electrometer) enabled easier measurement of attached coatings. This measurement [2] was still essentially measuring the same thing i.e. the DC resistance of the combined system. (A fuller discussion of the history [3] can be found). Not too long after that the method of AC Impedance was beginning to be applied to coatings [4]. Since then a very large amount of work has been done since using EIS (Electrochemical Impedance Spectroscopy) and in fact an ISO standard is currently being worked on. Later around 1988 the DC Transient method was introduced by Sykes and this has since been further developed by Tanabe [5]. In the late 80's/early 1990's the Electrochemical Noise Method (ENM) was first applied to coatings [6] (This early work was presented at a predecessor of this conference fifteen years ago). This was followed by further work by Bierwagen et al [7,8] and subsequently by the current author with a couple of students ; Steve Mabbutt [9,10,11] and more recently Christopher Woodcock [12]. Overall a wide variety of coating systems have been looked at using ENM. In the early/Mid 90s at NDSU [7,8] a range of intact solvent base coatings were continuously monitored in sea water for the US Navy. Samples were 50 cm<sup>2</sup> and measured in sextuplicate. In the mid/late 90's the ENM method was used at UCN to examine water based coatings and also to monitor the scribe [10, 11]. In the late 90s the single substrate method was developed [13,14] and in the 2000s continuous automated ENM monitoring has been used to assist a local paint company to develop a range of lower solvent coatings [12].

The main advantage of any of these electrochemical methods is that they give you a number. They are not accelerated methods as such but they enable you to compare quickly (more quickly than can be achieved by visual examination) coatings which have been subjected to immersion tests, cabinet tests or external exposure. But which to use? Well each one has pluses and minuses. DC Resistance is the simplest but most intrusive as voltages up to 1V are commonly employed (although this can be reduced). The most common method in well equipped laboratories with trained personnel is Electrochemical Impedance Spectroscopy and hence this ISO Standard mentioned above is being developed specifically for this technique [15]. Like DC Transient, this method gives more information (e.g. it can separate out under certain circumstances the corrosion reaction from the paint film resistance) but both are complex to operate and interpret. Electrochemical Noise Method on the other hand is not intrusive and is easily automatable. However in the standard arrangement it needs two nominally identical specimens which is a practical disadvantage. Some details on the two most popular electrochemical methods follow.

### **AC Impedance (EIS)**

In this method a small alternating current is imposed on the system and the phase shift is analysed. This is done over a range of frequencies (e.g. 10 KHz down to say 0.01Hz). Typical R.M.S. values of the imposed voltage might be 100mV or 10mV. Generally the data is presented as Nyquist (linear) and Bode (log) plots.

The claim is made that the corrosion system can be modeled as an equivalent circuit and that under ideal conditions EIS plots can provide separate values of Polarisation resistance, Coating resistance and Solution resistance. Mechanistic information can also be obtained from Nyquist plots particularly at scribes where resistances are low. However when conducting intact paints work very high resistances are being measured and the paint resistance dominates. Because of the difficulty of

comparing samples numerically (as many as 100 different data points are typically obtained) people resort to taking just one number e.g the  $R_p$  which is where in the Nyquist plot, the semi-circle intersects the x axis . They may also calculate the Coating Capacitance because this relates to water uptake. However note that the resistance has been shown many times to be a more effective predictor of anti-corrosive ability than capacitance.

## ENM

An easier method for at least the smaller paint companies and users to get to grips with is the Electrochemical Noise Method (ENM). (The company that the author has working with most recently now uses ENM as the standard method for assessing and monitoring its anti-corrosive coatings in conjunction with DC Resistance at end of testing). ENM needs 3 electrodes – two nominally identical coated substrates which constitute the two working electrodes (WEs) and one Reference electrode (typically a calomel electrode inserted into the solution). (Note that the configuration and designation of these three electrodes can be varied and a paper elsewhere in this conference [16] will discuss a new novel arrangement which avoids the need for connection to the substrate when using ENM). In the standard bridge method there is a salt bridge connecting WE1 and WE 2. The voltage is measured between the WE and reference and the current between the two WE. Data is gathered over say 5mins at 0.5 sec intervals (512 data points). Thus a ZRA and a computer are needed. The arrangement is shown in Figure 1. Equipment is available commercially from ACM, Gamry, and CML. Some of this equipment can be battery operated and taken out on site.

Fig. 1 Diagram for bridge method

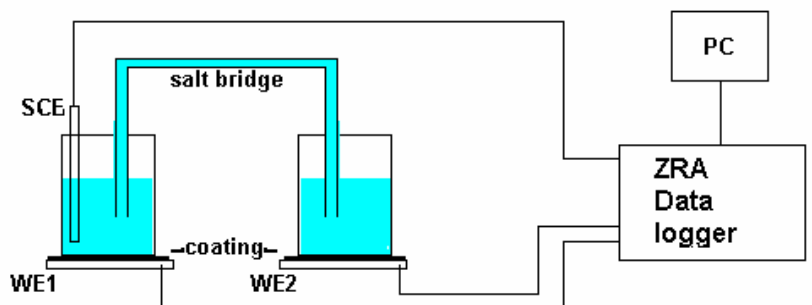

The theory of ENM is that, from the natural voltage and current fluctuations generated in corrosion cells (Figure 2) the derived parameters voltage Noise ( $\sigma_v$ ) and Current Noise ( $\sigma_i$ ) can be obtained. These parameters are used in an Ohms Law relationship to calculate Noise Resistance ( $R_n = \sigma_v / \sigma_i$ ). It has previously been shown that  $R_n$  correlates with Polarisation Resistance ( $R_p$ ) for bare metal and it has also been shown (and will be demonstrated again here) that  $R_n$  for a coated specimen correlates with DC Resistance ( $R_{dc}$ ). The biggest advantage of the method is that it is electrically non-intrusive i.e. the measurement does not disturb the sample being examined. Hence one can continuously monitor if one so wishes.

(Normally a comparison is done with DC resistance at the end of a test)

Fig. 2 Diagram of Noise plot

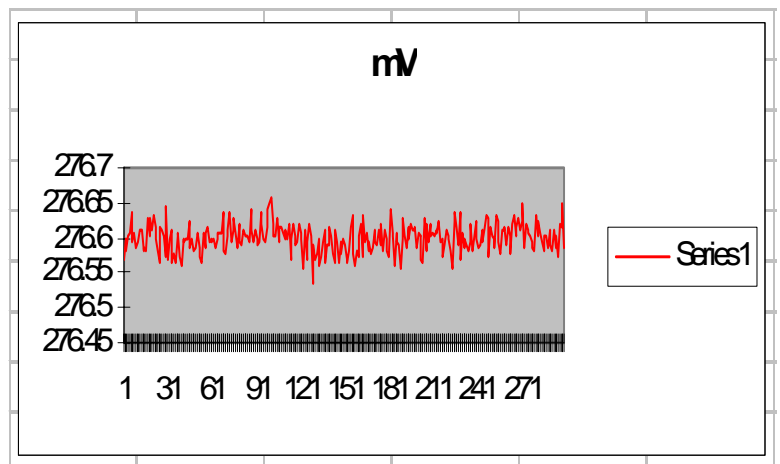

## Experimental

In the first work done at UCN (S. Mabbutt) the substrate was as received and degreased steel Q panel. The coating application was 2 coats by spreader bar – 100 microns (approx.) The solution used (for intact coatings) was typically 3% NaCl. The solution used for scribed coatings was Harrison's Solution (3.5% Ammonium sulphate, 0.5% NaCl) diluted by 10X. A circular cell was fixed on using silicone sealer. Exposed area was 11.8 cm<sup>2</sup> (bridge method)

Coatings examined were solvent based coatings e.g. 2 pack epoxy pigmented using zinc phosphate, pigmented alkyd using zinc tetroxy chromate, red lead primer, non-inhibitive alkyd and waterborne coatings e.g. 2 pack epoxy non-pigmented, acrylic styrene co-polymer emulsion (Neocryl), vinyl acrylic co-polymer latex (Haloflex).

The Scribe was produced using a Laser (cutting conditions : Lamp 1.7 kW, Pulse width 0.5 mS, Rate 200 Hz, Feed rate 70 mm/min Nitrogen shield, pressure 5.5 bar) or by Mechanical coating removal using specially developed tool (design by S Mabbutt) Typical Ablation dimensions were 2cm x 0.02cm.

### Experimental arrangements and Results (ENM)

As mentioned above there are different experimental arrangements for ENM work. Most data using ENM has been obtained using the Standard Bridge method shown in Figure 1. Some recent results obtained from a range of coatings using this method are shown in Figure 3. There is also the Single Substrate method which is a development of the bridge method – this can be used to assess in a practical situation e.g. at a panel exposure site. It is shown in Figure 4. Some results using the single substrate method in comparison with the normal bridge method and the DC resistance are shown in Figures 5 and 6.

Fig. 3 Graph showing use of ENM to help develop new paints

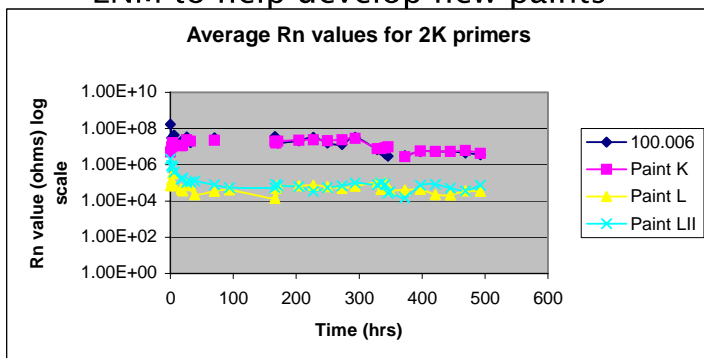

Fig. 4 Diagram for Single substrate method

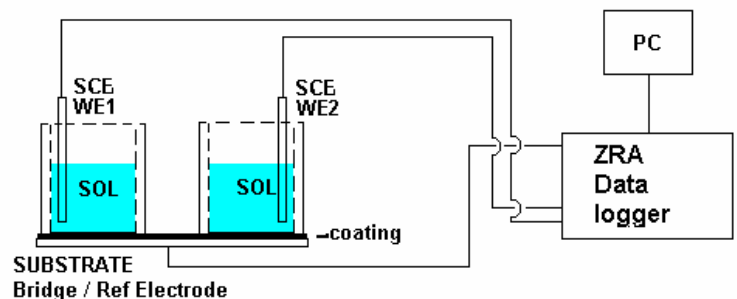

Fig. 5 Graph showing Comparison of SS and Bridge Method using CM epoxy on Fe in 10% Harrison's solution

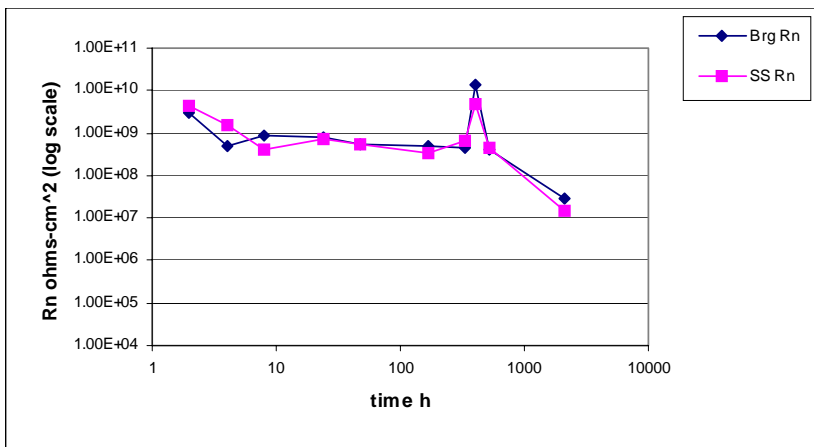
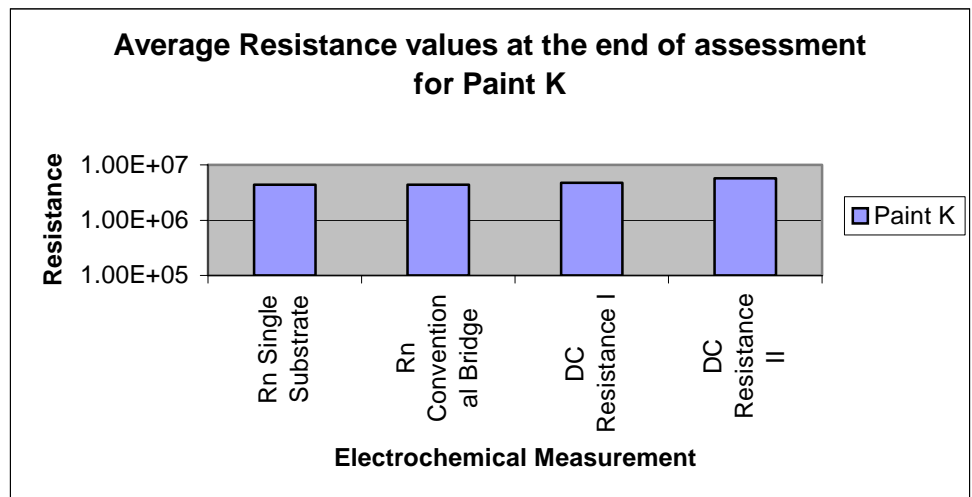
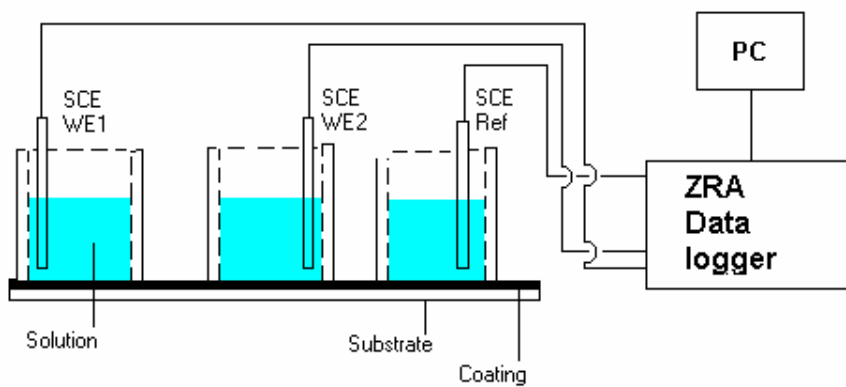

Fig. 6 Bar chart showing Comparison of single substrate bridge and DC resistance for paint K



Furthermore there is the NOCS Method which is shown in Figure 7. This is a further development involving no connection to the substrate. Results using this arrangement have been described elsewhere [16].

Fig. 7 Diagram of NOCS Method



A bar chart comparison of DC resistance with Electrochemical Noise ( $R_n$ ) for solvent alkyd is shown in Figure 8. A graph using ENM to compare a group of intact coatings is shown in Figure 9. A graph showing ENM to compare three scribed coatings is shown in Figure 10.

Fig. 8 Bar chart comparison of DC resistance with Electrochemical Noise for solvent alkyd

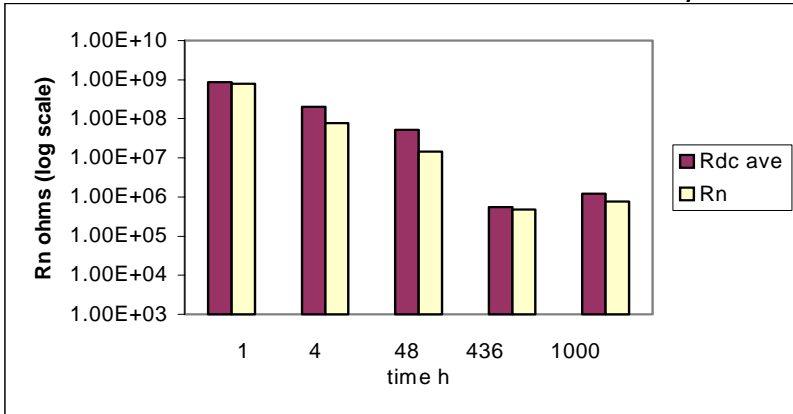

Fig. 9 Graph using ENM to compare a group of intact coatings

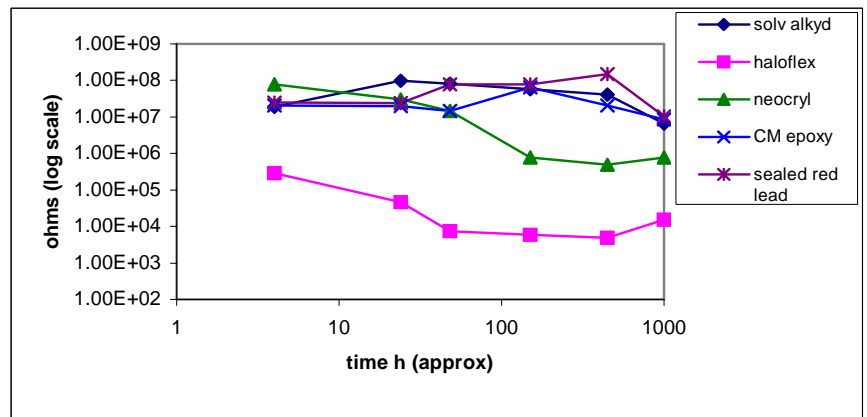
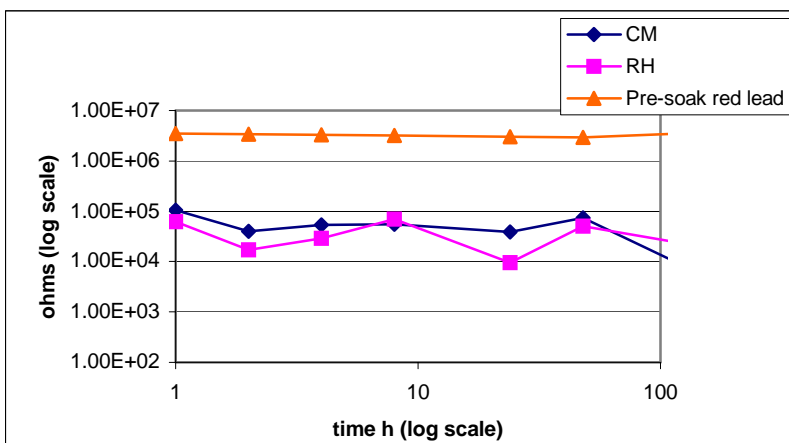

Fig. 10 Graph showing ENM to compare three scribed coatings



## AC data ( Method and results)

The experimental arrangement for AC measurement (EIS) is shown in Figure 11.

Figure 12 shows a Nyquist plot for scribed specimen and Figure 13 shows a time line for  $R_n$  (from ENM) versus  $R_p$  (from EIS) for a laser ablated (scribed) alkyd coating. Note that  $R_p$  is calculated from the Impedance data and is the limit impedance value as illustrated in Figure 12. This is the distance between the right and left hand intersections (or extrapolation) of the Nyquist semi-circle on the x-axis, (in practice the left hand intersection is often the zero point).

Fig. 11 Figure showing EIS measurement method

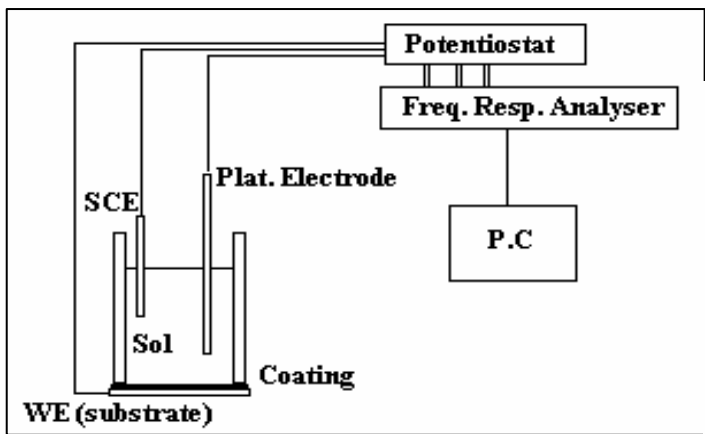

Fig. 12, showing EIS Nyquist plot for scribed specimen

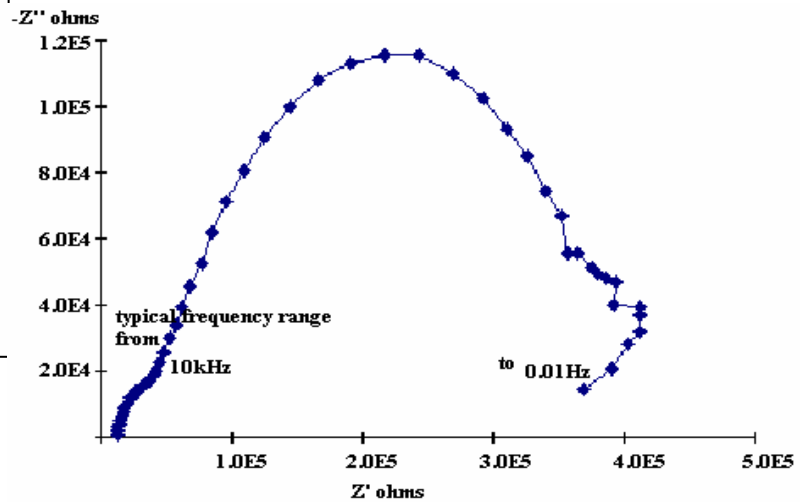
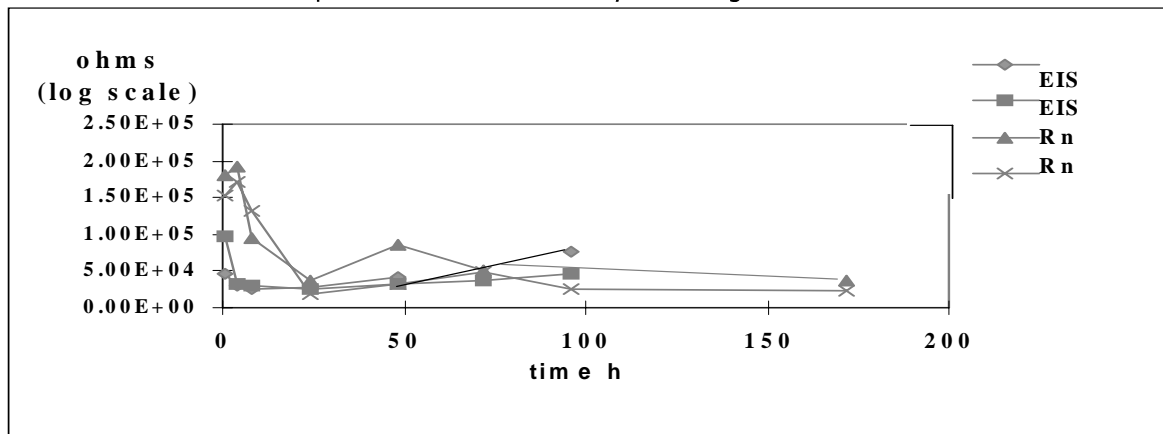

Fig. 13 Showing EIS versus  $R_n$  for a scribed alkyd coating  
(time line for  $R_n$  versus  $R_p$  for a laser ablated alkyd coating)



Two relatively recent papers [17,18] have used both EIS and ENM on similar samples and found reasonable correlation. EIS has also been used practically in the field [19].

### Method of measuring in triplicate and getting out individual values

When using electrochemical techniques a NOCS (No Connection to the Substrate) arrangement is obviously useful (In the case of EIS this matter is addressed in work done by Thompson and Campbell [19]). Whichever method is used (e.g. DC resistance, EIS, ENM) it will be necessary to make several measurements. Typically three areas are examined and three measurements of resistance between three pairs are made.

A NOCS development of ENM where measurements are made on three samples is presented elsewhere [16]. Experimentally if using the DC Resistance method with NOCS one would insert a reference electrode (e.g. SCE) into each cell and connect one to the high, the other to the low of the Electrometer. If using EIS method with NOCS then one would insert a reference (e.g. SCE) and counter (e.g. Pt) into one cell and insert another Reference into the other (connect latter to WE terminal on box). In both cases one makes three resistance measurements X,Y and Z (see Fig. 14)

Fig. 14 Universal NOCS arrangement allowing measurement in triplicate

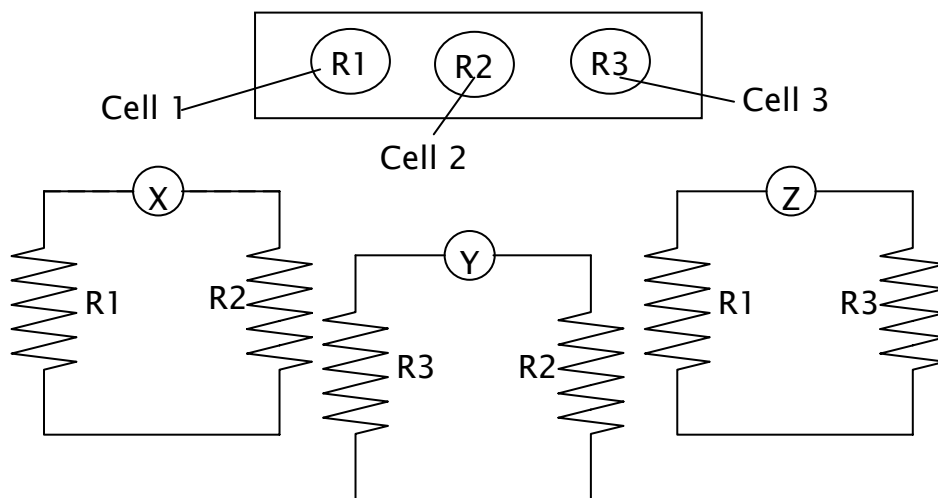

## Then if

- $R1 + R2 = X$
- $R2 + R3 = Y$
- $R1 + R3 = Z$

Measure X,Y, Z can solve for R1, R2 and R3

E.g.  $R1 = X - Y + Z / 2$  etc

The above analysis should work well for EIS and DC resistance. With ENM NOCS there are six possible arrangements (ways of connecting WE1, WE2 and Ref to R1, R2, R3 -experimental and theoretical work still needs to be done to enable calculation of R1, R2, and R3 from six measurements

## Discussion

It is not intended to discuss the results shown in figures 3,9,10 (ENM) or 12,13 (EIS) in any great detail (they have been discussed in previous publications [9-12] ). They are presented here to illustrate what is typically measured. They show that ENM, like EIS, is a useful electrochemical technique for monitoring paints and for assisting formulation. Time lines from continuous monitoring enable results to be obtained quickly and information can be gathered not only about intact coatings but also about the ability to protect at a scribe.

The question arises as to whether there is evidence that when used to get out a single resistance measurement (ie  $R_n$ ,  $R_p$  or  $R_{dc}$ ), ENM, AC Impedance/EIS, and DC resistance all measure the same thing? Certainly the values cannot necessarily be expected to be exactly the same. One reason for this is that the physical arrangement is different in the case of ENM compared with EIS or DC. ENM interrogates two samples (the  $R_n$

value would appear to be close to the geometric mean of the two DC values [20]) whereas a DC resistance or AC impedance value is based on measurement of a single sample. In relating the AC Impedance value with DC Resistance, the AC 0.1 Hz value has been shown to be very similar to the DC value taken after 10 seconds (that is if the coating system is acting largely as a resistor– if it is acting very much as a capacitor it will be root two times that value). This assumes that the resistance is independent of voltage (DC value normally obtained using 1 Volt, AC using 10–100mV)

Do experiments confirm this? Certainly when two techniques are compared (e.g. DC and ENM as shown in Figure 8 here ; or EIS compared with ENM in Fig 13 and in references [17, 18]), results have been similar :  $R_{dc}$  correlates with  $R_n$  and  $R_p$  from Impedance correlates to  $R_n$  .

So if it is accepted that they all measure the same thing what is it actually that is being measured? In theory when using ENM there is no direct way of telling whether it is an ionic resistance, a polarisation resistance or a diffusion to the interface (Warburg type) type resistance (this also applies to DC resistance type measurement) that is being evaluated (this is as compared to EIS when it is apparent which type of resistance it is from the shape of the Nyquist plot and/or the time constant of the semi-circle). However in practise the resistance value's dependence on voltage (normally close to ohmic) and the fact that resistances are normally high (greater than 1 Mohm) means that it is most likely to be an ionic resistance that is being measured. This is also borne out by most coating data gathered using AC impedance which, when plotted in Nyquist form, tend either to show a straight line response (pure capacitor) or a single semicircle. So it is the author's contention that in the vast majority of cases with intact films (as opposed to scribes) what is being measured using ENM, DC resistance, EIS (and probably DC transient also), is the ionic resistance of the coating system. Even when using ENM or DC resistance if the measurement is found to be low (and therefore may be the polarisation resistance or a Warburg type resistance), the value is still

a measure of the protective ability of the paint system as, by definition, if the resistance is low the paint is not very protective at least as regards being a barrier to ions. As previously demonstrated this ability to be an effective ionic barrier is the paramount property of a paint system. However when studying scribes, it is more likely to be a polarization resistance or Warburg resistance that is being measured rather than an ionic resistance (A simple test (e.g. voltage dependence) could be devised to check which it is).

It would appear from the foregoing that when measurements are made with the purpose of getting from the data a single resistance value, any of the three methods (ENM, EIS or DC Resistance) will produce similar results. Which method one chooses will depend on what is available and the level of expertise of the operator (in order of complexity : DC resistance is simpler than ENM which is simpler than EIS).

The author accepts that the experimental work reported here and/or reviewed here relating to the comparison of the methods is somewhat sketchy. Also comparison has not been made with the DC transient method. A systematic study comparing ENM, EIS, and DC and also comparing them with the DC transient method on a range of coated samples is really required. The author would hope to do this in the not too distant future.

This paper has also discussed the practical application of the techniques; particularly arrangements which require no connection to the substrate. The two methods of EIS and DC resistance have been shown to be capable of working under such conditions and be capable of measuring in triplicate quite easily. Current developments in experimental set-ups of ENM are extending its scope in this regard.

## Conclusions

- ENM, EIS and DC resistance are all useful for assessing coatings on metal substrates although the author has a preference for ENM because of its non-intrusive nature. There is evidence that, with intact films at least, the most useful number obtained using any of these three methods is a measurement of the through-film ionic resistance and all three methods can produce this
- Not only intact coatings can be assessed and monitored using these methods but also information about the ability to protect at a scribe can be obtained.
- Together with advances in data processing (not discussed in detail here), developments currently taking place in experimental set-ups is making easier application of all three methods to practical situations.
- Theoretically the NOCS approach can be applied with DC and EIS and can indicate reproducibility by measuring in triplicate. The ability of ENM to work with NOCS and hence give similar information is currently being investigated.

## Future- suggestions

- Encourage academia to work with instrument manufacturers to get them to produce a dedicated user friendly paint testing device based on an electrochemical method and also to develop these methods to increase their user-friendliness
- Develop methods for on-site continuous monitoring to get instant readouts of state of the coating systems
- Get more paint companies and users of coatings familiar with these useful methods

- Do everything possible to assist production of a standard practise for measurement of coated samples using ENM and EIS.
- Conduct a systematic study comparing ENM EIS and DC on a complete range of coated samples. (Also it would be good to include the DC transient method).
- Practical work to show how NOCS can be used with three samples using DC Resistance and AC Impedance measurement and then extend it to ENM

## References

1. Bacon R.C., T. J. Smith and R. M. Rugg, Ind. Eng. Chem, 40, p161–167, 1948
- 2 Mayne J. E. O. and D. J. Mills, JOCCA, 58, 155, 1975
3. Kendig M., Scantlebury J. D. and Mills D. In: Corrosion Science: A Retrospective and Current Status, In Honour of Robert P. Frankenthal, (Frankel G., Scully J. R., Isaacs H. S., Sinclair J. D, eds.), The Electrochemical Society,. PV 2002–13 pp. 419–429 2002
4. Callow L. M. and Scantlebury J. D., J. O. C. C. A. 64. 119 1981
5. Nagai M., Taki T. T., Tanabe H. and Kano H, Advances in Corrosion Protection by Organic Coatings III (Proc. conf. Noda, Japan Oct 1997) EdsScantlebury. J. D., Kendig M.and Mills D. J. Pub. The Electrochemical Society PV 97–41 pp 199–205 1998
- 6 Skerry B. S. and Eden D. A. Corrosion Protection by Organic Coatings, Conference, Christ's College, Cambridge, Electrochemical. Soc. Proc. Vol 89–13, pp 373– 393. 1989
7. Bierwagen G.P., Mills D.J., Tallman D.E., Skerry B.S., Proceedings

of the Conference on Electrochemical Noise for Corrosion Applications  
1994, publ. ASTM, 1996.

8. Mills D. J., Berg S. and Bierwagen G. P., Advances in Corrosion  
Protection by Organic Coatings II, PV 95-13, 82-97, (eds) Kendig M. and  
Scantlebury J. D., Electrochemical Society, 1995

9. Mills D. J., Mabbutt S. J., Lyon S. B. and Badger S., Proc. 14<sup>th</sup> Int. Corr.  
Congress, paper 86, Cape Town, S. Africa, Sept 1999

10 Mills D.J., Mabbutt S.J. Prog. Org. Coat. 39 41-48. 2000

11. Mabbutt S. and Mills D. J. Surface Coatings International Part B:  
Coatings Transactions Vol 84 B4 p 277-283 Nov 2001

12. Mills D. J., Singh T. and Woodcock C. P. Workshop : Electrochemical  
Methods for examining Organic Coatings Sintra, Portugal Oct 23<sup>rd</sup>-26<sup>th</sup>  
2003 (accepted by Progress in Organic Coatings – publication early 2005)

13. Mabbutt S. J. and Mills D. J. British Corrosion Journal, Vol. 33, 2, pp  
158-160 1998

14. Mabbutt S.J., Bierwagen G.P., Mills D.J., Anti-Corrosive Meth. 398  
Mater. 49 (4) 264-269 2002

15 ISO 16773 Standard practise for Electrochemical impedance  
spectroscopy on high impedance coated samples (Draft as at Nov 2004)

16 Woodcock C. P., Mills D. J. and Singh H. T. Proceedings Conf :  
Advances in Corrosion Protection by Organic Coatings Christ's College  
Sept 2004 To be published in JCSE

17. Conners K. D., Van Ooij W. J., Mills D. J. and Bierwagen G. P. British  
Corrosion Journal 35 No 2 141-144 2000

18. De Cristofaro N., Mengaroni E. and Fedrizzi L. Proceedings on CD  
ROM EuroCorr 2004 Nice France Sept 26-29<sup>th</sup> 2004

19. Thompson I. and Campbell D. Corrosion Science, Vol. 37, No. 1, pp. 67-78, 1995

20. Bierwagen G. P. et al Report for US Navy – (Programme Manager J Sedricks) Dept of Polymers and Coatings North Dakota State University 1995

## **Acknowledgements**

- Steve Mabbutt for being prepared to work on this project from 1996 to 2000 and make great strides with it and for producing most of the data presented here.
- Christopher Woodcock for providing some of the data for this paper and for useful discussions
- Pronto Industrial Paints (Technical Director : Tony Singh) for providing the more recent paint samples and supporting the work through a TCS scheme
- School of Applied Sciences at University College Northampton (Dean of School : Dr Nick Boutle) for supporting the work

## List of Figures

Figure 1 Diagram for bridge method

Figure 2 Diagram of Noise plot

Figure 3 Graph showing use of ENM to help develop new paints

Figure 4 Diagram for Single substrate method

Figure 5 Graph showing Comparison of SS and Bridge Method using CM epoxy on Fe in 10% Harrison's solution

Figure 6 Bar Chart showing Comparison of single substrate bridge and DC resistance for paint K

Figure 7 Diagram for NOCS Method

Figure 8 Bar Chart comparison of DC resistance with Electrochemical Noise for solvent alkyd

Figure 9 Graph using ENM to compare a group of intact coatings

Figure 10 Graph showing ENM to compare three scribed coatings

Figure 11 Figure showing EIS measurement method

Figure 12 Figure showing EIS Nyquist plot for scribed specimen

Figure 13 Showing EIS versus  $R_n$  for a scribed alkyd coating (time line for  $R_n$  versus  $R_p$  for a laser ablated alkyd coating

Figure 14 Universal NOCS arrangement allowing measurement in triplicate